



T2V003 Europe User Manual

Video Clips for
Testing and Optimisation of
Video Compression



www.testvid.com

Intentionally blank

This User Manual contains full information on the video files that you/your organisation has licensed for use.

Please ensure to read the next two pages for details of how these video clips may be used, within the terms of the License Agreement

To find particular video clips that contain specific features/subjects that you wish to test for, it is recommended that you use the PDF version of this manual as this allows fast electronic searching for specific clip features using the "CF-words" (see section 5.2 for more information).

T2V003_Europe User manual v1.0b

'T2Vid' and 'T3Vid' are trademarks of TestVid Ltd.

TestVid Ltd., 4 Cheyne Road, Bristol BS9 2DH, United Kingdom
www.testvid.com sales@testvid.com Tel.: +44 (0)117 949 6411

© 2011, TestVid Ltd., All rights reserved

TestVid Content License Agreement

This Content License Agreement (this "Agreement") governs the terms by which you ("You" or "Your") obtain the right to use video files, music files, sound effects files, creative art, 3-D animations, computer animations, motion backgrounds, camera acquired video footage, photos, flash files, project files, music files, data files and other material (collectively referred to as "Content") supplied by TestVid Ltd ("TestVid"). This Agreement is in addition to the TestVid Terms and Conditions of Sale ("Terms and Conditions") which are incorporated herein by reference and to which You will be contractually bound upon Your first use of the Content. In the event of any inconsistency between this Agreement and the Terms and Conditions, this Agreement shall govern. Any capitalized term that is not defined in this Agreement shall have the same meaning as set out in the Terms and Conditions.

GENERAL INFORMATION REGARDING THIS AGREEMENT

USE OF ANY OF THE TESTVID CONTENT INDICATES FULL AGREEMENT TO THE TERMS OF THIS AGREEMENT, EITHER FOR YOURSELF OR ON BEHALF OF YOUR COMPANY OR EMPLOYER (WHETHER ACTING AS AN EMPLOYEE, CONTRACTOR, SUB-CONTRACTOR, CONSULTANT OR IN ANY OTHER CAPACITY), AND AGREE TO BE BOUND BY ITS TERMS. IF YOU ARE ACCEPTING ON BEHALF OF YOUR COMPANY OR EMPLOYER, YOU REPRESENT AND WARRANT THAT YOU HAVE FULL LEGAL AUTHORITY TO BIND YOUR COMPANY OR EMPLOYER. IF YOU DO NOT HAVE SUCH AUTHORITY OR YOU DO NOT ACCEPT OR AGREE WITH THESE TERMS, DO NOT USE THE CONTENT.

LICENSE TERMS

Upon Your acceptance of this Agreement and receipt of payment from You by TestVid, TestVid grants to You a perpetual, non-exclusive, non-transferable license to use the Content for the Permitted Uses (as outlined below). The use contemplated by You must be a Permitted Use. If it is not, it is prohibited by this Agreement. All other rights in and to the Content, including, without limitation, all copyright and other intellectual property rights relating to the Content, are retained by TestVid.

Content is Licensed (not sold)

Your use of the Content is under license only. No title or intellectual property rights are granted to You. Ownership of the Content and all copyright and all other rights not expressly granted by this Agreement remains with TestVid.

Permitted Uses for the Content

Subject to the restrictions described under **Content License Restrictions & Prohibited Uses** below the following are "Permitted Uses" of the Content:

1. testing, development, engineering and related activities including product demonstrations and tests;
2. on-line or electronic presentations, catalogues, brochures, advertising and promotions including web pages, podcasts and vidcasts providing that when used for this purpose the version of the Content displayed (a) must be compressed such that any version that appears to be as good quality as the original cannot be obtained, and (b) the TestVid logo remains visible, and (c) there is a clear label denoting the TestVid copyright;
3. any other uses approved in writing, in advance by TestVid.

For clarity, You may not use the Content in products for resale, license or other distribution, unless approved in writing in advance by TestVid.

Content License Restrictions & Prohibited Uses

You may not do anything with the Content that is not expressly permitted in the preceding section or permitted by a separate modified content license which has been explicitly agreed in writing by TestVid. By way of example and not limitation, the following are "Prohibited Uses":

4. sale, resale or distribution of the Content either as a single piece of video, music file, sound effect file, composition, software project file or product or as a part of any background of these;
5. sale, resale or distribution of the Content as a part of another production where the Content, in our sole discretion, comprises 5% or more of the finished product;
6. incorporation of the Content in any product that results in a re-distribution or re-use of the Content or is otherwise made available in such a way one could extract or access or reproduce the Content as a separate file as if it were substantially unmodified;
7. sub-licensing, re-selling, renting, lending, assigning, gifting or otherwise transferring or distributing the Content or the rights granted under this Agreement;
8. removal of any notice of copyright, logo, watermark, trade-mark or other proprietary right from any place where it is on or embedded in the Content;
9. installation and use of the Content at a location/site other than for which the Content was originally licensed or placing a copy of the Content on a network server or web server for use by others at a different location/site;
10. use of the Content in a way which could be considered obscene, pornographic, immoral, infringing, dishonest, fraudulent, defamatory or libellous in nature, or that could be reasonably likely to bring any person or property reflected in the Content into disrepute;
11. use of or display of the Content in an electronic format that enables it to be downloaded or distributed as the original media file or with minor differences (as determined by TestVid) via any computer device (including mobile devices) or shared in any peer-to-peer or similar arrangement;
12. breaking the Content into smaller pieces and selling these pieces as stock or test media

Restriction on Quantity of Copies

Only You or bona-fide colleagues are permitted to use the Content, although You may transfer the Content or files containing the Content or Permitted Derivative Works to Your company's servers, for the purpose of reproduction for Permitted Uses, provided that such parties shall have no further or additional rights to use the Content and cannot access or extract it from any file You supply.

As long as it is a Permitted Use, You may reproduce the Content or any parts thereof in original or derivative forms (e.g. compressed) a maximum of 25 times on one particular 'site' (i.e. one geographical location, as determined at the discretion of TestVid).

If You require the Content to be copied or stored more than 25 times in original or derivative form, or require the Content or any parts thereof on a different site then You must purchase additional licenses for the Content. The count of number of copies covers all versions whether stored or used on personal computers, workstations, servers, web-servers, mainframes, laptops, PDAs, mobile phones and other mobile devices, games consoles and any other type of computer. For the avoidance of doubt, if the Content is stored at a remote site this Content may only be downloaded and used at the single site for which the license was purchased.

In addition to these 25 copies You may make one (1) copy of the Content solely for back-up purposes, and You must reproduce all proprietary notices on this single back-up copy.

Term of Agreement

This Agreement is effective until it is terminated. If You terminate this Agreement You must destroy or delete the Content and any Permitted Derivative Works, along with any copies or archives of it or accompanying materials (if applicable), and cease using the Content for any purpose. This Agreement and all of Your rights under it terminate automatically without notice if at any time You breach any of its terms. You must, if requested, confirm to TestVid in writing that You have complied with these requirements and provide any proof thereof requested by TestVid.

Amendment

This Agreement can be amended by TestVid at any time by posting an amended Agreement on TestVid's website. Your only recourse, if You are not agreeable to the amended Agreement is to terminate this Agreement and cease use of the Content. Otherwise, You will be bound by the terms of the amended Agreement.

Replacement of the Content

TestVid may revoke the license granted by this Agreement and replace the Content with a substantially similar alternative for any reason. TestVid may inform You of replacement of the Content by sending notice of same, along with the replacement Content to the address or contact information provided to TestVid by You or such other address as You may advise TestVid in writing to use. In the event of a replacement, the license for the replaced Content immediately terminates and this Agreement (or the then-current version of this Agreement) automatically applies to the replacement Content. You agree not to use the replaced Content, or any Permitted Derivative Works, for future products and to take all reasonable steps to discontinue use of the replaced Content, or any Permitted Derivative Works, in products that already exist.

Limitation of Warranties and Liability

While TestVid carefully all of the Content to ensure the highest quality, THE CONTENT IS PROVIDED "AS IS" WITHOUT REPRESENTATION, WARRANTY OR CONDITION OF ANY KIND, EITHER EXPRESS OR IMPLIED, INCLUDING, BUT NOT LIMITED TO THE IMPLIED REPRESENTATIONS, WARRANTIES OR CONDITIONS OF MERCHANTABILITY, OR FITNESS FOR A PARTICULAR PURPOSE. WE DO NOT REPRESENT OR WARRANT THAT THE CONTENT WILL MEET YOUR REQUIREMENTS OR THAT IT WILL BE ERROR FREE. THE ENTIRE RISK AS TO THE QUALITY AND PERFORMANCE OF THE CONTENT IS WITH YOU. SHOULD THE CONTENT PROVE DEFECTIVE, YOU ASSUME THE ENTIRE RISK AND COST OF ALL NECESSARY CORRECTIONS.

Our entire liability and Your exclusive remedy, with respect to any claims arising out of Your use of the Content, or out of Your actions in downloading the Content, shall be as follows: TESTVID'S MAXIMUM AGGREGATE LIABILITY UNDER THIS AGREEMENT OR IN RESPECT OF THE USE OR EXPLOITATION OF ANY OR ALL OF THE CONTENT IN ANY MANNER SHALL BE LIMITED TO THE FEES COLLECTED BY TESTVID FOR YOUR USE OF THE CONTENT THAT IS THE SUBJECT MATTER OF THE CLAIM OR \$1,000 UNITED STATES DOLLARS, WHICHEVER IS GREATER. IN NO EVENT SHALL TESTVID OR ANY OF ITS DIRECTORS, OFFICERS, EMPLOYEES, SHAREHOLDERS, PARTNERS, AGENTS OR LICENSEES BE LIABLE FOR ANY INCIDENTAL, INDIRECT, PUNITIVE, EXEMPLARY, OR CONSEQUENTIAL DAMAGES WHATSOEVER (INCLUDING DAMAGES FOR LOSS OF PROFITS, INTERRUPTION, LOSS OF BUSINESS INFORMATION, OR ANY OTHER PECUNIARY LOSS) IN CONNECTION WITH ANY CLAIM, LOSS, DAMAGE, ACTION, SUIT OR OTHER PROCEEDING ARISING UNDER OR OUT OF THIS AGREEMENT, INCLUDING WITHOUT LIMITATION THE USE OF, RELIANCE UPON, ACCESS TO, OR EXPLOITATION OF THE CONTENT OR ANY PART THEREOF, OR ANY RIGHTS GRANTED TO YOU HEREUNDER, EVEN IF TESTVID HAS BEEN ADVISED OF THE POSSIBILITY OF SUCH DAMAGES, WHETHER THE ACTION IS BASED ON AGREEMENT, TORT (INCLUDING NEGLIGENCE), INFRINGEMENT OF INTELLECTUAL PROPERTY RIGHTS OR OTHERWISE. IF YOUR JURISDICTION DOES NOT ALLOW THE EXCLUSION OF IMPLIED WARRANTIES OR FOR THE LIMITATION OR EXCLUSION OF LIABILITY FOR INCIDENTAL OR CONSEQUENTIAL DAMAGES, THE LIABILITY OF TESTVID OR ANY OF ITS DIRECTORS, OFFICERS, EMPLOYEES, SHAREHOLDERS, PARTNERS OR AGENTS SHALL BE LIMITED TO THE GREATEST EXTENT PERMITTED BY LAW.

Indemnity

You agree to indemnify, defend and hold TestVid and its affiliates, and their respective directors, officers, employees, shareholders and agents (collectively, the "TestVid Parties") harmless from and against any and all claims, liability, losses, costs and expenses (including reasonable legal fees) incurred by any TestVid Party as a result of (i) any breach by You of this Agreement; (ii) any claim threatened or asserted against any TestVid Party that alleges that You have breached this Agreement or infringed any copyrights, trade secrets, trademarks, right of privacy, right of publicity or other intellectual or other property rights of any third party. TestVid reserves the right, at Your expense, to assume the exclusive defence and control of any matter otherwise subject to indemnification by You, and You agree to cooperate with TestVid's defence of such claim.

General Provisions

You acknowledge and agree that this Agreement will be governed under the laws of the United Kingdom (without reference to conflicts of laws principles). You hereby irrevocably submit to the jurisdiction of the Courts of the United Kingdom. If TestVid is obligated to go to court or arbitration to enforce any of its rights, or to collect any fees, You agree to reimburse TestVid for its legal fees, costs and disbursements if TestVid is successful. You consent to service of any required notice or process upon You by registered mail or overnight courier with proof of delivery notice, addressed to the address or contact information provided by You at the time You first purchase usage rights to the Content. You agree to waive any right You may have to trial by jury. TestVid's failure to insist upon or enforce strict performance of any provision of this Agreement shall not constitute a waiver. This Agreement is not assignable by You without TestVid's prior written consent (such consent not to be unreasonably withheld). TestVid may assign this Agreement without Your consent to any other party so long as such party agrees to be bound by its terms. This Agreement may be amended by TestVid at any time by posting an amended Agreement on the TestVid website. Continued use of the Content or failure to terminate this Agreement after posting of such amendment will be deemed to be acceptance of the amendment.

YOU ACKNOWLEDGE THAT YOU HAVE READ THIS AGREEMENT AND HAVE HAD OPPORTUNITY TO SEEK INDEPENDENT LEGAL ADVICE PRIOR TO AGREEING TO IT. IN CONSIDERATION OF TESTVID AGREEING TO PROVIDE THE CONTENT, YOU AGREE TO BE BOUND BY THE TERMS AND CONDITIONS OF THIS AGREEMENT. YOU FURTHER AGREE THAT IT (AND ANY SUBSEQUENT MODIFICATION OF IT) AND THE TERMS AND CONDITIONS POSTED ON THE WEBSITE ARE THE COMPLETE AGREEMENT BETWEEN YOU AND TESTVID, AND THAT SAME SUPERSEDES ANY PRIOR AGREEMENT.

Contents

1. Overview of T2V003 Europe	1
2. Introduction	2
2.1 T2Vids and T3Vids for testing encoders	2
2.1.1 Audio.....	2
2.1.2 Software.....	3
2.2 T2Vids and T3Vids for testing decoders	3
2.3 <i>TestVid</i> logo	3
2.4 Safety.....	3
2.5 Backup.....	3
3. T2V003 Europe Clip set description	4
3.1 Set content types.....	4
3.2 Individual clips provided.....	4
3.2.1 Generation of interlaced video	5
3.3 Format of video on disk	5
3.3.1 1080p	5
3.3.2 720p	5
3.3.3 1080i	6
3.4 Audio.....	7
4. Software to view & process YUV video	8
4.1 Viewing/playing the YUV video	8
4.1.1 Computer requirements of viewing the YUV video.....	8
4.1.2 YUV viewers/players	8
4.1.3 Programs that do not display/import YUV files directly.....	8
4.1.4 Wrap the YUV within an AVI file	8
4.1.5 Convert YUV to another format.....	9
4.2 Real-time play-out of the YUV video	9
4.3 Software tools provided	10
4.3.1 License agreement relating to the software tools provided	11
4.3.2 yuvmake1088	11
4.3.3 yuvfieldcombine.....	11
4.3.4 yuvletterbox.....	12
5. List of clips	14
5.1 Clips summary.....	14
5.2 Clip features	19
5.2.1 PDF file searching for specific clip features	19
5.2.2 Excel file sorting for specific clip features	19
5.2.3 List of 'CF' ('clip features') words used.....	20
6. Detailed information on individual clips	22
6.1 Detailed description of each clip	22

1. Overview of T2V003 Europe

2-D / 3-D	2D
Compressed/ Uncompressed	Uncompressed
Description of video	Scenes from London, Barcelona, Bruges, Rome, Munich
Purpose	Test an encoder to deal with HD video, with all aspects of global and local motion, slow/medium/fast motion, with panning, scrolling, zooming, smooth and erratic, high/low contrast, with limited colours/vivid colours and many common subject types
Number of clips	201 individual video clips (67 each at 1080p, 720p and 1080i resolutions)
Length of video	Total of over 2 hours 15 minutes (over 45 minutes each at 1080p, 720p and 1080i resolutions)
Total size on disk	522 GBytes
Video format(s)	YUV 4:2:0 planar 8 bits per sample: <ul style="list-style-type: none">□ 1920x1080 progressive [original filming size, at 25 fps]□ 1280x720 progressive□ 1920x1080 interlaced, bottom field first
Audio format(s)	MPEG-1 Layer II stereo 384kbps CBR 16-bit 48kHz and WAV linear PCM uncompressed stereo 1536kbps 48kHz

2. Introduction

T2Vid and **T3Vid** are high definition (HD) video clips designed for testing video encoders and decoders.

The **T3Vid** clips are stereoscopic 3-dimensional (matched left and right images); the **T2Vid** clips are 2-D.

Both the **T2Vid** and **T3Vid** clips come in two variants: those designed to test and stress video encoders (usually in uncompressed YUV format, some of which have associated sound); and compressed video designed to test the range of options available in a standards-compliant video decoder (in compressed format such as MPEG-4/AVC/H.264 or MPEG-2, both as elementary streams and in 'wrappers' such as MPEG-2 Transport Stream).

2.1 T2Vids and T3Vids for testing encoders

Each set of clips for testing encoders contains a diverse selection of clips designed to stress a video encoder in different ways. Typically this includes different movement types, different subjects, different lighting conditions, different camera movement - designed to encompass the majority of different types of difficult-to-encode items. In some cases the quality of filming is marginal - deliberately so, as this is often the hardest to encode. The majority of the filming was done hand-held, as is quite often the case with documentary and even film currently. However, in all cases there has been no video editing as such (unless otherwise stated for a specific clip) - all the separate video clips are direct decodes from the HD camera files, with no re-compression/re-encoding done. Where video editing has been done the re-encode is only at the transitions - the vast majority of these clips are also as per the original camera files.

These clips are provided as sets of video clips, typically 30 - 50 in a set, lasting from 15 - 20 minutes total. These include:

- 'standard' HD of real-world subjects (1920x1080, 1280x720; e.g. in New York, San Francisco, London, Munich)
- as above but D-cinema resolutions (2K and 4K)
- as above but 'low' resolutions such as NTSC, D1 PAL, CIF, mobile, web, etc.
- synthetically generated, which has features such as precisely defined motion - ideal for checking such items as encoder motion estimation

The formats/resolutions provided vary from by clip set; as an example all the HD sets are provided at 1920x1080 progressive, 1920x1080 interlaced and 1280x720 progressive formats, in uncompressed YUV format, 16:9 aspect ratio.

All filming was done native HD.

Most clip sets are provided in 8 bits per sample; some are available at 10-bit or 14-bits per sample.

The **T2Vid** clips are straightforward 2-D clips; the **T3Vid** clips comprise matched left and right video images. The **T3Vid** clips have the 'extra dimension' of varying 3-D depth: from shallow to deep 3-D effect, into or out of the picture, with additional artefacts and difficulties that can be encountered in 3-D.

2.1.1 Audio

Sound is provided for almost all clips: in some cases this is sound recorded which is directly associated with the clips, in other cases the sound comprises appropriate background or music.

In a few cases the associated audio is one of the main reasons for recording the clip so both should be viewed together (where this is the case the notes state this for the specific clip in the manual). However, note that in most cases the associated audio provided is just that which could easily be recorded at the same time as the video, typically comprising background sounds, and is often of low quality as the sound was not the primary consideration at the time of filming.

2.1.2 Software

In addition to the video and audio, utility software to process the YUV video is provided as listed in section 4 and information on YUV viewers.

2.2 T2Vids and T3Vids for testing decoders

These are designed to test standards-compliant video decoders, by providing a series of video clips where the same video source material is encoded at different bit-rates with different encoder options.

Normally each clip is provided more than one format: typically MPEG-2 and MPEG-4/AVC/H.264 elementary video formats, at both 1920x1080 and 1280x720, as well as the source video in YUV format. In addition, each clip is typically encoded into one or more 'wrapper' formats such as MPEG-2 Transport Stream, with the associated audio in an appropriate format.

The associated audio is also provided as separate elementary files.

Full information on the currently available sets of **T2Vid** and **T3Vid** clips series is at www.testvid.com.

2.3 TestVid logo

The **TestVid** logo (or a variant of it) is usually placed in the lower left corner of the video. It is a condition of the license agreement for **TVids** that this logo is not removed or obscured.

The logo has been carefully sized and placed to coincide with the borders of a 16x16 macroblock (where this is possible) and is static throughout each sequence, in order to have minimal effect on encoders and decoders.

2.4 Safety

The **TVids** are almost invariably supplied on a USB hard drive unit. This unit may be mains powered or powered directly from the USB port.

In all cases it is imperative that you carefully read and understand the safety information provided with the unit.

2.5 Backup

As the **TVids** are almost invariably supplied on a USB hard drive unit it is highly recommended that you make an immediate backup of the whole unit, as hard drives can of course fail. (This backup copy is in addition to the 25 copies allowed by the license agreement.)

The warranty on the hard drive is 180 days, but if it does fail it would of course take some days at least to provide a replacement unit.

3. T2V003 Europe Clip set description

3.1 Set content types

This set of video clips comprise a range of subjects, motion, colours, light levels designed to test and stress video encoders by providing a varied set of conditions:

- ❑ subject types such as people, traffic, buildings, sky, water, trees, text..
- ❑ movement types such as panning, zooming in/out, tracking, hand-held camera
- ❑ subject motion such as into, out of or across the picture, in front of and partially behind objects
- ❑ lighting conditions, from bright sunlight, dull daylight, shaded areas, indoors..
- ❑ varying camera properties such as depth of field, in/out-of-focus..
- ❑ hard to encode items such as reflections, fine lines, patterns, round objects..
- ❑ and with sound associated with some clips

In many cases the video is harder to encode than might normally be expected, as the lighting conditions are not ideal or there is significant camera movement, or the focus varies. These features are deliberately used as they often cause the most difficulty to video encoders and represent the worst case that the encoder should encounter in 'normal / real' use.

The total time of the individual clips is over 2 hours 15 minutes (over 45 minutes in each of the formats).

3.2 Individual clips provided

201 YUV clips are provided, comprising 67 individual clips each at the following resolutions:

- ❑ 1920x1080 progressive [original filming size]
- ❑ 1280x720 progressive: this has been generated by downsizing from 1920x1080 using a proprietary scaling algorithm (superior to bicubic interpolation)
- ❑ 1920x1080 interlaced (see sections 3.2.1 and 3.3.3), comprising alternate fields with each field at 1920x540 resolution, bottom field first

Each of these clips are:

- ❑ planar YUV 4:2:0 (i.e. a frame of Y followed by a frame of U followed by a frame of V, where the U and V are both are half the resolution of the Y plane, both horizontally and vertically)
- ❑ 8-bits (one byte) per sample
- ❑ square pixels
- ❑ 16:9 picture aspect ratio
- ❑ no headers
- ❑ top picture row first
- ❑ Y planes are unsigned nominally 16-235 but may go 0-255
- ❑ U and V planes are centred at 128 and are nominally 16-240 but may go from 0-255

All of the clips were filmed at 25 frames per second, although the YUV may be re-played / encoded at any speed (such as 24 or 29.97 fps).

3.2.1 Generation of interlaced video

All the clips were originally filmed progressive. In order to generate the correct fields representing the video data at the time between the progressive fields, in-house software has been used. Normally this has been done by calculating pixel-by-pixel motion vectors from one frame to the next in order to generate the intermediate time frame. For the many of the clips this process works well: sometimes it does not due to excessive movement or other factors.

Where there are minor artefacts in the generated frames of the video these are noted in box GN.12 of the clip description (in order to ensure that these are not interpreted as encoder errors).

For video clips where the motion vector calculations produce a large number of artefacts, the intermediate fields have been generated by blending the preceding and following frames together. Where this is the case the 1920x1080i clip has been denoted below with 'Frame blend' in box GN.12.

All the generated interlaced clips are one frame shorter than the progressive clips upon which they are based (this is a by-product of the generation process).

3.3 Format of video on disk

All the YUV video is stored in planar form, i.e. a plane of Y followed by a plane of U followed by a plane of V.

3.3.1 1080p

Byte 0 in the file is the Y data of the pixel at top left of the first frame.

One frame of Y, U and V:

Plane of Y followed by plane of U followed by plane of V

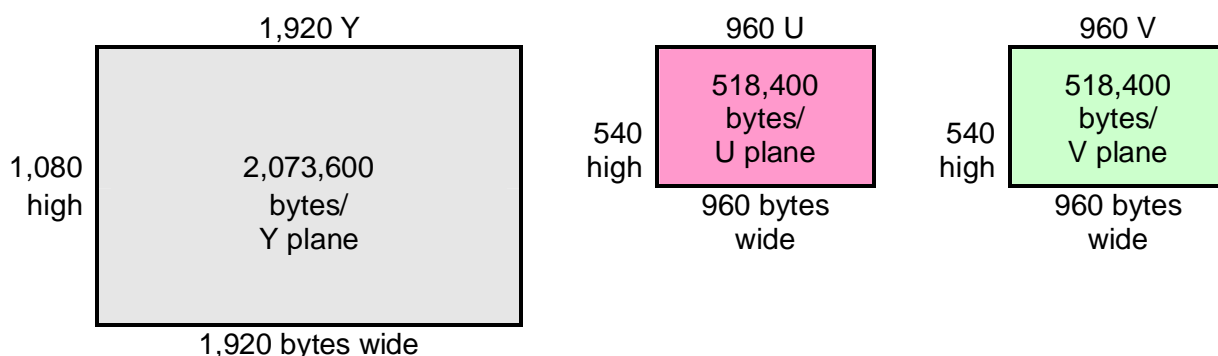

Valid video data ranges:

- Y: 16 - 235
- U and V: 16 - 240

3.3.2 720p

Byte 0 in the file is the Y data of the pixel at top left of the first frame.

One frame of Y, U and V:

Plane of Y followed by plane of U followed by plane of V

T2V003 Europe

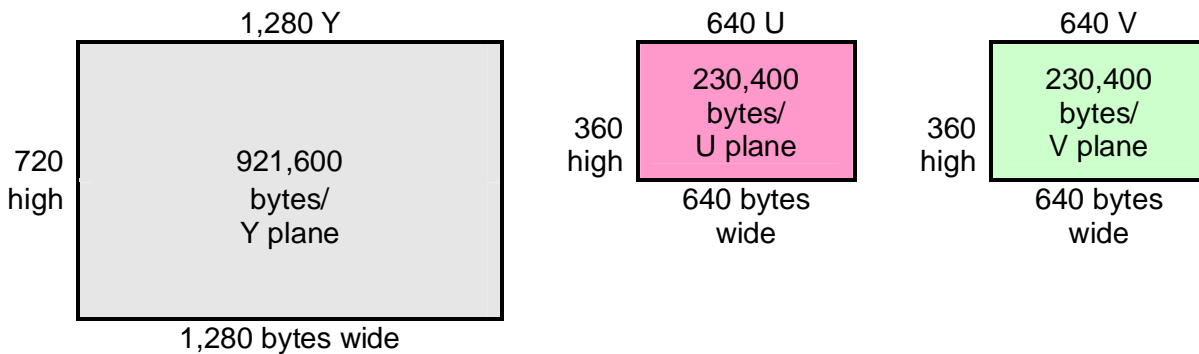

Valid video data ranges:

- Y: 16 - 235
- U and V: 16 - 240

3.3.3 1080i

Byte 0 in the file is the Y data of the pixel at top left of the first frame.

Note: as supplied, the 1080i video is stored on disk with alternating fields of YUV, bottom field first. If the 1080i video is required in frame format, with the alternating fields on alternating lines, the supplied utility program `yuvfieldcombine` can be used to combine the fields. See sections 3.2.1 and 4.3.3 for more information.

Each frame of Y, U and V is divided into alternating fields, bottom field first, with the YUV data as follows (each field being half the height of the frame):

BTM field			TOP field		
Y data BTM field	U data BTM field	V data BTM field	Y data BTM field	U data BTM field	V data BTM field

For each field: plane of Y followed by plane of U followed by plane of V

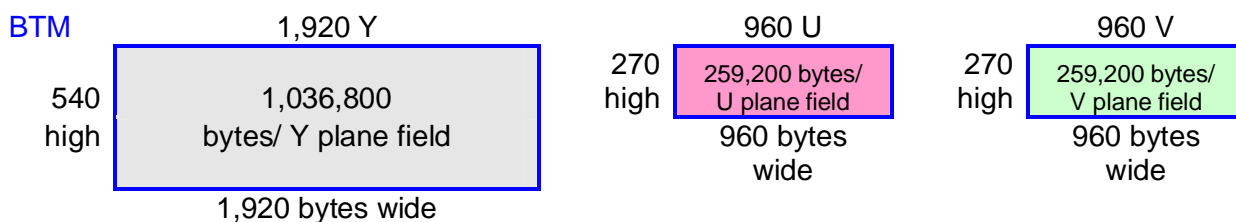

followed by top field:

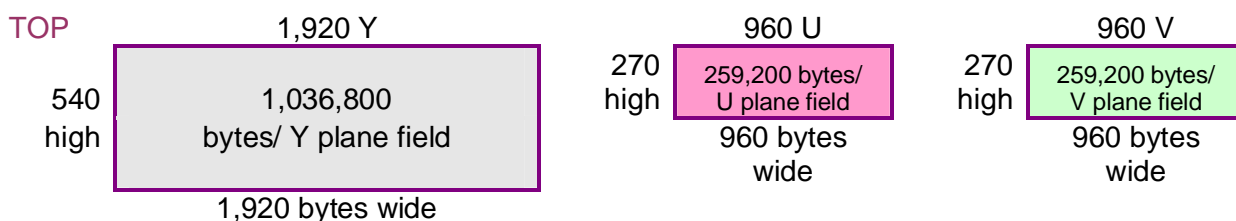

Valid video data ranges:

- Y: 16 - 235
- U and V: 16 - 240

3.4 Audio

Audio clips are provided for every video clip, matching the video length. In the vast majority of cases this was the actual audio recorded with the video.

Where the audio provided was not recorded with the video, similar/appropriate audio is provided, matched in time-length. This is denoted by `'_sim_'` in the audio filename (instead of `'_act_'`, denoting actual audio recorded at the time).

Clearly the main point of the *Tvids* is video testing, so the audio supplied is intended to be used to check timing/correlation during the encode process rather than to be particularly useful as standalone audio. Consequently, this audio has not been cleaned up or normalised and nor was time spent in ensuring good audio recording during filming.

All the audio clips are provided in two formats:

- MPEG-1 Layer II stereo 384kbps CBR 16-bit 48kHz and
- WAV linear PCM uncompressed stereo 1536kbps 16-bit 48kHz

4. Software to view & process YUV video

4.1 Viewing/playing the YUV video

This section explains some of the technical requirements for playing the YUV video (computer and software requirements).

4.1.1 Computer requirements of viewing the YUV video

The **Tvids** YUV files are uncompressed and some of the clips within this set require a high performance computer in order to play the video in real-time at full frame rates. The sustained continuous data rates required from disk are:

- ❑ **1080p/i:** 78 MBytes/sec
- ❑ **720p:** 35 MBytes/sec

This means that the above rates must be achieved using disk arrays, solid state disks or with the video loaded into RAM disk.

Useful references as starting points for system recommendations are given on the websites for Aja (www.aja.com) and BlackMagic Design (www.blackmagic-design.com) although various companies provide information about how this can be achieved / the configuration of system required to achieve this. A list is given on the **TestVid** website under Support at:

<http://www.testvid.com/highperfpc.html>

TestVid accepts no responsibility or liability for use of any of the information on the pages listed.

4.1.2 YUV viewers/players

There are a number of software programs for viewing YUV files: a list is given on the **TestVid** website under Support at:

<http://www.testvid.com/yuvviewers.html>

Links are provided to the pages where the YUV viewers can be downloaded.

Note that these programs only show one YUV stream at a time.

TestVid accepts no responsibility or liability for download or use of any of the programs listed; the user should carefully examine the license agreement that applies to the software concerned.

4.1.3 Programs that do not display/import YUV files directly

A number of common programs - such as Final Cut Pro, Adobe Premiere Pro, Sony Vegas and others may not import YUV uncompressed files directly: the YUV files may need to be wrapped e.g. in an AVI or converted to another format

- ❑ wrap the YUV within an AVI file
- ❑ convert the YUV into a different format acceptable to the chosen program
- ❑ play the YUV video out in real-time on SDI and use an adaptor to display the two SDI inputs

Each of the above options is discussed below.

4.1.4 Wrap the YUV within an AVI file

There are a number of programs to do this; probably the easiest is to use a program called **FFMPEG**. This is used as a command line program: it can easily be found using a search engine.

Usage:

```
ffmpeg -r 25 -s 1920x1080 -i <infile.yuv> -vcodec copy <outfile.avi>
```

where

- `-r 25` sets the frame rate to 25 fps (FFMPEG default is 25 fps)
- `-s 1920x1080` sets the resolution of the input file
- `<infile.yuv>` is the input YUV filename
- `<outfile.avi>` is the output AVI filename

Note that the 1920x1080 interlaced files are separate fields, with each field 1920 horizontal and 540 vertical. Most likely, it will be better to combine these separate fields into frames 1920 horizontal and 1080 vertical, before putting into an AVI: use the provided **TestVid** program `yuvfieldcombine` to do this (see section 4.3 below). The batch file provided does this.

Note that in order to use these batch files:

- firstly, the **Tvids** sequences will need to be copied to a different disk as there is insufficient space on the supplied disk unit
- secondly, the correct paths will need to be set up in the batch files, to FFMPEG and by doing a 'Search and Replace' (Ctrl-H in Windows Notepad)
- FFMPEG will need to be downloaded

4.1.5 Convert YUV to another format

As the purpose of this set of **Tvids** sequences is to test encoders (and presumably purchased for this purpose), the user will have a means to encode the YUV sequences into a compressed format such as MPEG-2, H.264/MPEG-4/AVC, MVC or other, so can then view the compressed sequences.

4.2 Real-time play-out of the YUV video

The YUV files provided are suitable for direct use with video encoders, but in some circumstances it may be desirable to play-out the YUV in real-time on an SDI / ASI / DVI / HDMI link.

Essentially, the issue is to get the uncompressed **Tvids** YUV files from disk onto an SDI / ASI / DVI / HDMI interface via a specialised I/O board.

All video servers, many hardware encoders and a large proportion of other professional broadcast equipment have internal hard disks and Gig-E Ethernet interfaces. This allows the **Tvids** to be directly copied over the Ethernet network onto the hard disk, and play-out from there.

Where it is required to produce an SDI / ASI / DVI / HDMI stream as input to other equipment, this can be done relatively straightforwardly, using:

- a high performance PC / Mac
- with high speed RAID hard disks
- with an appropriate SDI etc. I/O board, e.g. from Aja, BlackMagic Design or Bluefish444
- and software to control moving the video from disk onto the I/O interface

A schematic of the required set-up is:

Real-time Play-out Using a PC/Mac

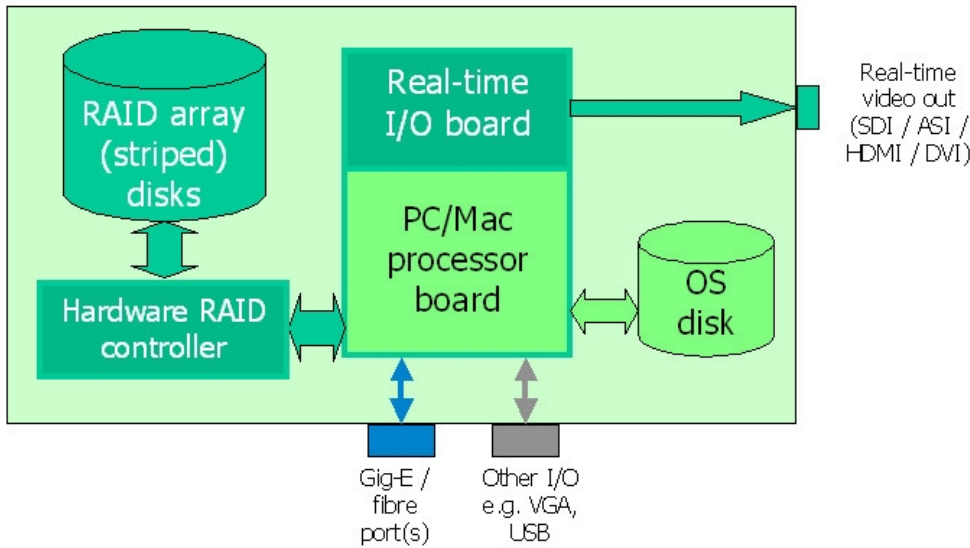

See the [TestVid](http://www.testvid.com) website:

<http://www.testvid.com/support.html>

More detailed information is provided, including a page on "broadcast applications" and the steps required are covered in some detail in the white paper, "Real-Time Play-out of YUV Video in a Broadcast Environment"

4.3 Software tools provided

The following software is provided:

Software tool	Purpose
yuvmake1088	Add extra lines at the top/bottom of a 1920x1080 YUV file to make it 1920x1088
yuvfieldcombine	Combine interlaced fields which are stored in alternating format (bottom field followed by top field, each half-height) into frames where alternate lines contain alternate fields
yuvletterbox	Alter provided video by making it appear 'letterboxed' (i.e. with black bands top and bottom of each frame) or 'pillarboxed' (with black bands left and right)

Note

1. The software tools are provided solely for the use of the purchaser of the license to use this set of video clips and may not be used with other video or provided to other persons/organisations.
2. The use of these software tools is only on the basis of complete acceptance of the license agreement as given in section below. The fact of using these software tools gives your explicit consent to abide by the terms of the license agreement.

4.3.1 License agreement relating to the software tools provided

This license agreement below applies to all software listed in this section 4.3.

The software program(s) is/are provided to the user without any license fee or royalty on an "as is" basis, solely as an incidental part of the clip set and do not form part of the contract.

TestVid disclaims any and all warranties, whether express, implied, or statutory, including any implied warranties or merchantability or of fitness for a particular purpose.

The user makes use of this/these program(s) at their own risk. In no event shall **TestVid** be liable for any incidental, punitive, or consequential damages of any kind whatsoever arising from the use of this/these program(s).

This disclaimer of warranty extends to the user of this/these program(s) and user's customers, employees, agents, transferees, successors and assigns.

The software program(s) is/are provided solely to the purchaser of the relevant set of **TVids** and may not be sent to or copied to any other person or organisation or used with any other video

4.3.2 yuvmake1088

This is a command line program for adding 8 additional lines to 1080 vertical resolution video, to make it 1088 vertically i.e. an integer multiple of 16.

All the lines added are greyscale, set to one grey colour.

Usage:

```
yuvmake1088 <inputfile.yuv> <p> <n> <c>
```

where

- <inputfile.yuv> is the input filename which is 1080 lines vertically (must have extension .yuv)
- <p> = progressive or interlaced input file, set to 'p' or 'i'
- <n> = the number of the 8 lines to add at the top of each frame (0, 2, 3, 6 or 8). '0' means add zero lines at the top i.e. at 8 lines at the bottom; '8' means add 8 lines at the top and zero at the bottom; '4' means add 4 at top and bottom, etc.
- <c> = greyscale colour to add, number 16-235. 16=black; 235=white. Numbers less than 16 will be set to 16; greater than 235 will be set to 235.

The filename for the output file, with the extra 8 lines added, will be

```
inputfile_1088.yuv (the '_1088' is added by yuvmake1088)
```

The output file is put in the same folder as the input file.

4.3.3 yuvfieldcombine

This is a command line program for combining interlaced fields which are stored in alternating format (bottom field followed by top field, each half-height) into frames where alternate lines contain alternate fields.

It is assumed that the video data is stored bottom field first.

Usage:

```
yuvfieldcombine <inputfile.yuv> <xsize> <ysize> <nnn>
```

where

- ❑ `<inputfile.yuv>` is the input filename (must have extension `.yuv`)
- ❑ `<xsize>` = horizontal resolution of the input file (must be multiple of 2)
- ❑ `<ysize>` = vertical resolution of **frame** of the input file, e.g. set to 1080 for 1920x1080i; set to 480 to 720x480i (must be multiple of 4)
- ❑ `<nnn>` = number of video frames to process. Set to 0 to process all frames. If `<nnn>` is greater than the number of frames then all frames will be processed

The filename for the output file, with the fields combined will be

`inputfile_FLDCMB.yuv` (the `'_FLDCMB'` is added by `yuvfieldcombine`)

The output file is put in the same folder as the input file.

4.3.4 yuvletterbox

This is a command line program for creating a black band at the top & bottom of each frame (or left & right), by over-writing the video data in these bands. The luminance of the 'black' band may be set; the size of the bands top and bottom (left/right) may be set. The *TVids* logo is moved to remain visible in the bottom left corner of the video data.

For interlaced video it is assumed that the video data is stored bottom field first.

1080p/i (1920x1080) and 720p (1280x720) videos are 16:9 picture aspect ratio (1.777:1).

Common picture aspect ratios with areas of letterbox / pillarbox are:

Picture aspect ratio	1080p/i (1920x1080)	720p (1280x720)
Default	Number of black lines top & bottom	
1.777:1 (16:9)	0, 0	0, 0
Letterbox	Number of black lines top & bottom	
1.85:1	21, 21	14, 14
2.35:1	131, 132	87, 88
Pillarbox	Number of black lines left & right	
1.33:1 (4:3)	240, 240	160, 160
14:9 (1.56:1)	117, 118	78, 79

Usage:

```
yuvletterbox <inputfile.yuv> <xsize> <ysize> <nnn> (cont'd)
                <f> <blk> <l> <tl> <br>
```

where

- ❑ `<inputfile.yuv>` is the input filename (must have extension `.yuv`)
- ❑ `<xsize>` = horizontal resolution of the input file (must be multiple of 2)
- ❑ `<ysize>` = vertical resolution of **frame** of the input file, e.g. set to 1080 for 1920x1080i (must be multiple of 4)

- `<nnn>` = number of video frames to process. Set to 0 to process all frames. If `<nnn>` is greater than the number of frames then all frames will be processed
- `<f>` = format, i.e. progressive or interlaced input file, set to 'p' or 'i'
- `<blk>` = 'black' colour to add, number 16-235. 16=black; 235=white. Numbers less than 16 will be set to 16; greater than 235 will be set to 235.
- `<l>` = letterbox or pillarbox, set to 'l' or 'p'. If set to 'l' (for letterbox) then the values for `<t1>` and `
` are used respectively for the top and bottom of the video; if set to 'p' (for pillarbox) then the values for `<t1>` and `
` are used respectively for the left and right of the video
- `<t1>` = the number of the lines (columns) to over-write at the top (left) of each frame with the `<blk>` value. Valid values are 0 to 400
- `
` = the number of the lines (columns) to over-write at the bottom (right) of each frame with the `<blk>` value. Valid values are 0 to 400

As an example:

```
yuvletterbox inputfile.yuv 1920 1080 0 p 16 l 21 21
```

will produce a letterboxed version of the `inputfile.yuv` file, 1920x1080, all frames, progressive, black colour 16, with 21 black lines top and bottom (making a visible picture aspect ratio of 1:85:1)

The filename for the output file, with the letterboxed/pillarboxed content will be























```
inputfile_LBOX.yuv    if <l> = 'l', or (the '_LBOX' is added by yuvletterbox)
inputfile_PBOX.yuv    if <l> = 'p', or (the '_PBOX' is added by yuvletterbox)
```

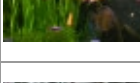

The output file is put in the same folder as the input file.

5. List of clips





5.1 Clips summary













□ Total time of clips at each resolution (at 25 fps): **45 mins 46 secs 14 frames**

Clip number(s)	Title	Main purposes	Duration (mins:secs:frames) at 25fps	Begin	End
T2V003001, T2V003101, T2V003201	Bars_countdown	Monitor set up; text	00:50:00		
T2V003002, T2V003102, T2V003202	Big_Ben	Rapid motion tracking and linear detail patterns with bright colours and large monochromatic areas	00:17:13		
T2V003003, T2V003103, T2V003203	Red_leaves	Shallow focus on detailed natural patterns and irregular global motion	01:01:24		
T2V003004, T2V003104, T2V003204	Priest	Compression of facial features with objects passing behind and in front	00:49:06		
T2V003005, T2V003105, T2V003205	Eye_pod	Slow global motion with high contrast	02:23:18		
T2V003006, T2V003106, T2V003206	Angled_ride	Fast global motion	00:29:00		
T2V003007, T2V003107, T2V003207	Duckman	Compression of bright and rounded features with quick movement	00:47:19		
T2V003008, T2V003108, T2V003208	Green_weed	Macroblock motion vectors in high contrast image, with small particles in front of objects	00:34:04		
T2V003009, T2V003109, T2V003209	Service_road	Low movement low contrast with similar areas with reflections and scene transition	00:28:24		
T2V003010, T2V003110, T2V003210	Neon_tunnel	Medium speed leftwards global motion with rapid irregular motion and bright changing colours	01:05:16		
T2V003011, T2V003111, T2V003211	Pidgeon_bully	Compression of fur-like detailed features with shallow focus	00:39:21		
T2V003012, T2V003112, T2V003212	Red_white_crane	Rapid global and macroblock motion vector tracking behind objects	00:22:04		

T2V003013, T2V003113, T2V003213	A_real_pro	Compression of people with limited global movement but passing objects	00:40:14		
T2V003014, T2V003114, T2V003214	Raindrops	Irregular random objects (raindrops) with patterns and fine detail	00:32:07		
T2V003015, T2V003115, T2V003215	Dough_head	Grainy and dark images with medium speed global motion	00:46:24		
T2V003016, T2V003116, T2V003216	Polizia	Text and people compression with limited then rapid global motion and macroblock motion vector tracking	01:31:09		
T2V003017, T2V003117, T2V003217	Beer_festival	High contrast early evening images with some very bright and some dark grainy images with people	00:31:15		
T2V003018, T2V003118, T2V003218	Mind_the_wall	Compression of very rapidly moving patterns (rapid but consistent global motion and macroblock motion vectors)	00:21:04		
T2V003019, T2V003119, T2V003219	Little_girl	Random but relatively slow global motion with zoom in and tracking person with people obscuring view	00:51:11		
T2V003020, T2V003120, T2V003220	Red_cloths	Low movement high contrast compression efficiency check with slight global movement	00:12:21		
T2V003021, T2V003121, T2V003221	Incy_spider	Fine detail compression against contrasting background with slow global zoom out, zoom in and focus change	00:58:02		
T2V003022, T2V003122, T2V003222	In_honorem	Compression of text in low contrast image with irregular vertical movement and regular horizontal movement	00:25:11		
T2V003023, T2V003123, T2V003223	Girls_appear	Shallow focus on very grainy image then on people with scene change and global zoom out	00:36:12		
T2V003024, T2V003124, T2V003224	Street_vendors	Partly out-of-focus on people at varying distances with low contrast background	00:19:12		
T2V003025, T2V003125, T2V003225	Parliament	Medium speed global motion left with high contrast and detailed patterns	00:32:19		
T2V003026, T2V003126, T2V003226	Flower_focus	Brightly sunlit natural patterns with focus shifting and zoom out	01:14:02		

T2V003027, T2V003127, T2V003227	Pimlico_bus	Rapid macroblock tracking with increasing feature size	00:42:10	
T2V003028, T2V003128, T2V003228	No_party	Mainly low movement grainy image with high contrast text and reflections, with some rapid up/down and random global motion and scene change	01:03:00	
T2V003029, T2V003129, T2V003229	Two_girls	Rapid global motion left and macroblock motion vectors	00:12:19	
T2V003030, T2V003130, T2V003230	Boten_Stael	High contrast sunlit image with slow global zoom out and motion down to areas with dark shadow	00:37:06	
T2V003031, T2V003131, T2V003231	Bike_woman	Medium speed tracking of motion vectors with frequently obscured subject and opposite direction global motion in highly patterned image	00:32:11	
T2V003032, T2V003132, T2V003232	Leaning_column	Compression of angled object and text with low-contrast pattern (stone) and light monochromatic background	00:17:08	
T2V003033, T2V003133, T2V003233	Rippling_water	High contrast high reflection high grain rapid movement: very hard for motion vector correlation/tracking	00:09:05	
T2V003034, T2V003134, T2V003234	Buggy_ride	Obscured subject and multiple objects moving in each direction with over-bright background (level changing)	01:39:03	
T2V003035, T2V003135, T2V003235	Windfarm	Low contrast rotating objects and rapidly varying focus	00:28:01	
T2V003036, T2V003136, T2V003236	Cargo_boat	Tracking linear object moving on water with round and detailed pattern objects in background	00:43:09	
T2V003037, T2V003137, T2V003237	Fat_bird	Efficiency of compression with limited movement but detailed natural objects and visible grain	00:29:22	
T2V003038, T2V003138, T2V003238	Striped_Tshirt	Motion vectors of increasing size objects (people) with strong patterns	00:13:08	
T2V003039, T2V003139, T2V003239	Globes	Slow global zoom out with round objects and rapidly changing focus	00:18:16	
T2V003040, T2V003140, T2V003240	Lion_fish	Motion vector tracking slow moving natural high-contrast patterns	01:01:12	

T2V003041, T2V003141, T2V003241	London_bridge	Slow scroll up with patterns and some movement	00:13:05		
T2V003042, T2V003142, T2V003242	Police_launch	Motion vector tracking with random high-contrast background (water)	00:17:11		
T2V003043, T2V003143, T2V003243	Nelsons_monument	Slow global scroll down with irregular shapes and patterns and irregular small global movement	00:25:19		
T2V003044, T2V003144, T2V003244	Train_ride	Fast but limited random global motion in any direction	02:25:21		
T2V003045, T2V003145, T2V003245	Just_sitting	Low movement high contrast compression of people	00:42:03		
T2V003046, T2V003146, T2V003246	Squid	Round natural objects with reflections	00:35:22		
T2V003047, T2V003147, T2V003247	That_hurts	Macroblock motion vectors of people with objects in front and behind	00:19:04		
T2V003048, T2V003148, T2V003248	Lit_fountains	High contrast indistinct objects (water) rapidly changing position and colour in grainy image	01:18:00		
T2V003049, T2V003149, T2V003249	4x4_track	Macroblock motion tracking with rapid global motion to the left, with objects in front and behind	00:38:24		
T2V003050, T2V003150, T2V003250	Sloped_walk	Macroblock motion vectors	00:42:24		
T2V003051, T2V003151, T2V003251	Subway_follow	Random very rapid global and macroblock motion with dark images	01:01:01		
T2V003052, T2V003152, T2V003252	Catwalk	Highly patterned high contrast curved object	00:22:10		
T2V003053, T2V003153, T2V003253	Clock_tower	Macroblock motion vectors of identical mirrored areas with detail but monochromatic background	00:10:17		
T2V003054, T2V003154, T2V003254	Going_up	Slow global zoom out	00:30:20		
T2V003055, T2V003155, T2V003255	Going_down	Fine detail / moire patterns with some reflections	00:24:10		

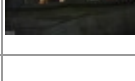
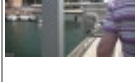
T2V003056, T2V003156, T2V003256	Vatican_traffic	Complex scene with multiple objects for motion vector tracking, with scene jump	00:21:17		
T2V003057, T2V003157, T2V003257	Passing_harbour	Very rapid global motion left in high contrast scene	00:39:14		
T2V003058, T2V003158, T2V003258	Las_Ramblas	Slow macroblock motion vector tracking of people	00:34:02		
T2V003059, T2V003159, T2V003259	Gaudi_church	Slow scroll up with fine detail against monochromatic background and particle scene change	00:42:11		
T2V003060, T2V003160, T2V003260	Reflections	Limited movement with reflections and large and small patterns	00:37:15		
T2V003061, T2V003161, T2V003261	Night_columns	Left/right regular rotational global motion with similar patterns and natural textures	00:18:16		
T2V003062, T2V003162, T2V003262	Water_up	High contrast image macroblock motion vector tracking with random angled motion	00:25:11		
T2V003063, T2V003163, T2V003263	Dummy	Motion vector tracking of obscured objects in grainy picture with slow global zoom out and scroll down and fade scene change	00:28:17		
T2V003064, T2V003164, T2V003264	Cable_cars	Limited slow macroblock movement but frequent small rotational global movement, with monochrome background	00:49:22		
T2V003065, T2V003165, T2V003265	Ceiling_rotate	Rotating global motion in dark extremely grainy image with some highlights	00:18:17		
T2V003066, T2V003166, T2V003266	Rowing_sailing	Macroblock motion vectors with complex scene and finely defined objects with random objects (water) and minor scene change	01:25:08		
T2V003067, T2V003167, T2V003267	Sky_clouds	Slow uniform global motion and macroblock tracking of indistinct irregular shapes	01:03:06		

5.2 Clip features

5.2.1 PDF file searching for specific clip features

The PDF of the user manual may be searched to find clips that match the given CF-words ('CF'= Clip Feature).

5.2.2 Excel file sorting for specific clip features

In addition to the PDF of this manual, an Excel file is provided which lists all the clips and the clip features in columns. This spreadsheet is in Excel .xls format (compatible with Excel versions from 97-2000 and later).

There are two tabs in the spreadsheet:

- the first tab has the clip set title: this has all the items listed in the manual for the clip
- the second tab "Clip features" just lists the individual clips, with the list of their clip features and individual columns for each individual clip feature.

Probably the "Clip features" tab is easiest to use to find specific clips with specific features, although every column may be sorted for specific features, by clicking on the drop-down arrow adjacent to each column heading (the examples below are from the T2V001 USA East clip set)

1	A	B	C	D	E	F	G
2	Number(s)	Title	Filename(s)	Horizontal x vertical size	Progressive / Interlaced	Video format	Bits per sample
3	T2V001001, T2V001101, T2V001201	Bars_countdown	T2V001001_Bars_countdown_1920x1080p.yuv	1920x1080; 1280x720	'p' file suffix = progressive; 'i' YUV planar 4:8	(for each of 'HD color	
4	T2V001002, T2V001102, T2V001202	Stars_n_Stripes	T2V001002_Stars_n_Stripes_1920x1080p.yuv	1920x1080; 1280x720	'p' file suffix = progressive; 'i' YUV planar 4:8	(for each of 'US flag	
5	T2V001003, T2V001103, T2V001203	Times_Square	T2V001003_Times_Square_1920x1080p.yuv	T2 1920x1080; 1280x720	'p' file suffix = progressive; 'i' YUV planar 4:8	(for each of 'Some	
6	T2V001004, T2V001104, T2V001204	Chrysler_building	T2V001004_Chrysler_building_1920x1080p.yuv	1920x1080; 1280x720	'p' file suffix = progressive; 'i' YUV planar 4:8	(for each of 'Slow zo	
7	T2V001005, T2V001105, T2V001205	Display	T2V001005_Display_1920x1080p.yuv	T2V0011(1920x1080; 1280x720	'p' file suffix = progressive; 'i' YUV planar 4:8	(for each of 'Large o	

Click arrow to get drop-down list of items in this column (example below for 'SS.01 People')

AC	AD	AE	AF	AG
C.10	LC.11	SS.01	SS.02	SS.03
-	Some	(All) (Top 10 .) (Custom...)	One	-
-	-	-	-	-
-	-	Few	-	-
-	-	Many	-	-
-	-	One	-	-
-	-	People	-	-

Select 'One' to show only clips with 'One' under 'SS.01 People'

Note that this first tab on the spreadsheet is roughly 100 columns wide (from column A to column CZ), so it may be helpful to use the 'Freeze Panes' feature (on the 'Window' menu in Excel 2000 and 2003) or split windows to keep the clip number visible.

The "Clip features" tab appears and can be sorted as indicated below:

1	A	B	C	D	E	F	G
2	Clip number / name	Clip features	CF-animal	CF-angl	CF-bandin	CF-black_bac	CF-bright_da
2	T2V001001_Bars_countdown	CF-text, CF-dark_areas, CF-patterns, CF-black_background, CF-round_objects, CF-transitions, CF-large_monochromatic				y	
3	T2V001002_Stars_n_Stripes	CF-bright_colours, CF-large_monochromatic, CF-movement_across					
4	T2V001003_Times_Square	CF-panning, CF-complex_scene					
5	T2V001004_Chrysler_building	CF-zoom_in, CF-fine_details, CF-low_contrast, CF-dull_daylight					
6	T2V001005_Display	CF-high_contrast, CF-rapid_changes					
7	T2V001006_Smiling	CF-faces, CF-people					
8	T2V001007_Traffic_duty	CF-faces, CF-text, CF-people					
9	T2V001008_Empire_State	CF-patterns, CF-scroll, CF-faces, CF-hand_held					
10	T2V001009_FDNY	CF-out_of_focus, CF-vehicles					
11	T2V001010_Checked_caps	CF-people, CF-movement_out, CF-patterns					
12	T2V001011_Gold_statue	CF-water, CF-patterns, CF-large_monochromatic					
13	T2V001012_Eyewitness_news	CF-moving_text					

Selecting a drop-down menu and clicking on 'y' reduces the list to those that have that CF value:

Clip number / name	Clip features
4 T2V001003 Times_Square	CF-panning, CF-complex_scene
34 T2V001033 People_crossing	CF-complex_scene, CF-vehicles, CF-people
36 T2V001035 Pan_left	CF-panning, CF-complex_scene, CF-tracking
45 T2V001044 Times_Sq_night	CF-night, CF-complex_scene, CF-dark_areas, CF-transitions, CF-scene_change, CF-graininess
48 T2V001047 Broadway	CF-night, CF-text, CF-complex_scene

5.2.3 List of 'CF' ('clip features') words used

The PDF of the user manual may be searched to find clips that match the given CF-words ('CF'= Clip Feature).

- | | | |
|------------------------|-----------------------|-------------------------------|
| CF-bright_sunlight | CF-bright_daylight | CF-dull_daylight |
| CF-indoors_bright | CF-sunrise_sunset | CF-twilight |
| CF-night | CF-indoors_dark | CF-shaded |
| CF-light_picture | CF-dark_areas | CF-brightness_change |
| CF-high_contrast | CF-low_contrast | CF-black_background |
| CF-bright_colours | CF-dull_colours | CF-highlights |
| CF-large_monochromatic | CF-monochromatic | CF-white_background |
| CF-scene_change | CF-transition | CF-subjects_behind_foreground |
| CF-movement_in | CF-movement_out | CF-movement_across |
| CF-rapid_movement | CF-random_movement | CF-low_movement |
| CF-movement_up/down | CF-diagonal_movement | CF-coordinated_movement |
| CF-hand_held | CF-angled | |
| CF-zoom_in | CF-zoom_out | |
| CF-panning | CF-scroll | CF-from_above |
| CF-tracking | CF-tracking_following | |
| CF-out_of_focus | | |
| CF-people | CF-faces | CF-crowd |
| CF-talking_head | CF-round | CF-vehicles |
| CF-text | CF-buildings | CF-leaves |
| CF-water | CF-reflections | CF-trees |
| CF-patterns | CF-fine_details | CF-lines |

CF-moire

CF-clouds

CF-sky

CF-complex_scene

CF-graininess

CF-animals

CF-banding

CF-speeded_up

CF-sound_talking

6. Detailed information on individual clips

The following pages provide detailed information on the clips in this set.

6.1 Detailed description of each clip

This section contains detailed descriptions of each video clip, and the associated audio.

70 features are listed for each clip: the purpose of providing these descriptions is to make it easier to select specific clips for specific features.

Therefore even if a characteristic does occur in a particular clip, this is not necessarily listed where it is not a prominent feature and/or where it is believed that the clip would not be selected for this particular feature.

Clearly to some extent these descriptions and selections are subjective, and the user is likely to come to their own conclusions as to which are most relevant to their particular codec / situation: the descriptions provided are intended to be an appropriate starting point.

Bars countdown



GN.01	Filename(s)	T2V003001_Bars_countdown_1920x1080p.yuv T2V003101_Bars_countdown_1280x720p.yuv T2V003201_Bars_countdown_1920x1080i.yuv
GN.02	Horizontal x vertical size(s)	1920x1080; 1280x720
GN.03	Progressive / Interlaced	'p' file suffix = progressive; 'i' file suffix = interlaced
GN.04	Video format	YUV planar 4:2:0
GN.05	Bits per sample	8 (for each of Y, U, V)
GN.06	Video description	HD colour bars and countdown with title slate, black segment and audio tone & pips
GN.07	Principal purposes	Monitor set up; text
GN.08	Duration (mins:secs:frames) at 25 fps *	00:50:00
GN.09	No. of frames (1080i 1 less *)	1250
GN.10	1080i generation / artefacts	Motion tracking
GN.11	Original video format	1080p25; 720p25
GN.12	File size(s) on disk (MB)	3,888 : 1,729: 3,882
GN.13	CF words	CF-text, CF-dark_picture, CF-patterns, CF-black_background, CF-round_objects, CF-transitions, CF-large_monochromatic
GN.14	Associated audio types	MPEG1 Layer II 48kHz 16bit stereo 384kbps Constant Bit Rate 16bit uncompressed 48kHz stereo WAV
GN.15	Associated audio filenames	T2a003x01_Bars_countdown_act_MP1LII.mpa T2a003y01_Bars_countdown_act_unc.wav
GN.16	Associated audio description	1kHz audio tone and pips on countdown
GN.17	Audio duration	Same as video (video played at 25fps)

Clip features		Details	SCENE SUBJECTS		
LIGHT CONDITIONS			SS.01	People	-
LC.01	Bright sunlight	-	SS.02	Faces	-
LC.02	Bright daylight	-	SS.03	Vehicles	-
LC.03	Dull daylight	-	SS.04	Buildings	-
LC.04	Shaded areas	-	SS.05	Trees	-
LC.05	Indoors bright	-	SS.06	Text	Some
LC.06	Indoors dark	-	SS.07	Talking head	-
LC.07	Twilight	-	SS.08	Water	-
LC.08	Sunrise/sunset	-	SS.09	Leaves/grass	-
LC.09	Night	-	SS.10	Sky	-
LC.10	Backlighting	-	SS.11	Clouds	-
LC.11	Large brightness change	Some	SS.12	Patterns	Some

SS.13	Round objects	One	SM.04	Movement up/down	-
SCENE PROPERTIES			SM.05	Diagonal movement	-
SP.01	Depth of field	-	SM.06	Subjects behind foreground objects	-
SP.02	Out-of-focus	-	SM.07	Low movement	Yes
SP.03	Fine lines / moiré patterns	-	SOUND CONTENT		
SP.04	Reflections	-	SC.01	Talking	-
SP.05	Scene change	4	SC.02	Movement	-
SP.06	Fades	-	SC.03	Vehicles	-
SP.07	Transitions	4	SC.04	Wind	-
SP.08	Slow/fast motion	-	SC.05	Music	-
COLOURS & CONTRAST			SC.06	Background	-
CC.01	Light picture	Most	SC.07	Other	1kHz tone
CC.02	Dark picture	Black	SOUND CHARACTERISTICS		
CC.03	Bright colours	Some	SH.01	Mono/ stereo	Stereo
CC.04	Dull colours	-	SH.02	Average volume	Mid
CC.05	Fine detail/moiré patterns	-	SH.03	Level changes	-
CC.06	High contrast areas	Some	SH.04	Clear/ distorted	-
CC.07	Large monochromatic areas	Some			
CC.08	Graininess	-			
CC.09	Black background	10 seconds			
CC.10	White background	-			
GLOBAL MOTION					
GM.01	Fast track/pan	-			
GM.02	Tracking in/out	-			
GM.03	Tracking	-			
GM.04	Panning	-			
GM.05	Tracking (following)	-			
GM.06	Fast scroll	-			
GM.07	Scroll	-			
GM.08	Angled	-			
GM.09	Zoom in	-			
GM.10	Zoom out	-			
GM.11	Hand-held camera	-			
SUBJECT MOTION					
SM.01	Movement out of picture	-			
SM.02	Movement into picture	-			
SM.03	Movement across picture	-			

Big_Ben



GN.01	Filenames	T2V003002_Big_Ben_1920x1080p.yuv T2V003102_Big_Ben_1280x720p.yuv T2V003202_Big_Ben_1920x1080i.yuv
GN.02	Horizontal x vertical size(s)	1920x1080; 1280x720
GN.03	Progressive / Interlaced	'p' file suffix = progressive; 'i' file suffix = interlaced
GN.04	Video format	YUV planar 4:2:0
GN.05	Bits per sample	8 (for each of Y, U, V)
GN.06	Video description	Looking up at London bus passing in front of Big Ben
GN.07	Principal purposes	Rapid motion tracking and linear detail patterns with bright colours and large monochromatic areas
GN.08	Duration (mins:secs:frames) at 25 fps *	00:17:13
GN.09	No. of frames (1080i 1 less *)	438
GN.10	1080i generation / artefacts	Frame blend
GN.11	Original video format	1080p25
GN.12	File size(s) on disk (MB)	1,362 : 605 : 1,359
GN.13	CF words	CF-bright_daylight, CF-buildings, CF-fine_details, CF-large_monochromatic, CF-monochromatic, CF-movement_across, CF-round, CF-scroll, CF-sky, CF-subjects_behind_foreground, CF-vehicles
GN.14	Associated audio types	MPEG1 Layer II 48kHz 16bit stereo 384kbps Constant Bit Rate 16bit uncompressed 48kHz stereo WAV
GN.15	Associated audio filenames	T2a003x02_Big_Ben_act_MP1LII.mpa T2a003y02_Big_Ben_act_unc.wav
GN.16	Associated audio description	Actual audio recorded with video
GN.17	Audio duration	Same as video (video played at 25fps)

Clip features	Details			
		LC.10	Backlighting	-
		LC.11	Large brightness change	-
LIGHT CONDITIONS				
LC.01	Bright sunlight	-		
LC.02	Bright daylight	All		
LC.03	Dull daylight	-		
LC.04	Shaded areas	-		
LC.05	Indoors bright	-		
LC.06	Indoors dark	-		
LC.07	Twilight	-		
LC.08	Sunrise/sunset	-		
LC.09	Night	-		
SCENE SUBJECTS				
		SS.01	People	-
		SS.02	Faces	-
		SS.03	Vehicles	Buses
		SS.04	Buildings	One
		SS.05	Trees	-
		SS.06	Text	-
		SS.07	Talking head	-
		SS.08	Water	-

SS.09	Leaves/grass	-	GM.04	Panning	-
SS.10	Sky	Monochromatic blue	GM.05	Tracking (following)	-
SS.11	Clouds	-	GM.06	Fast scroll	-
SS.12	Patterns	Many	GM.07	Scroll	Slow Up
SS.13	Round objects	Few	GM.08	Angled	-
SCENE PROPERTIES			GM.09	Zoom in	-
SP.01	Depth of field	Deep	GM.10	Zoom out	Once, fast
SP.02	Out-of-focus	-	GM.11	Hand-held camera	-
SP.03	Fine lines / moiré patterns	-	SUBJECT MOTION		
SP.04	Reflections	-	SM.01	Movement out of picture	-
SP.05	Scene change	-	SM.02	Movement into picture	-
SP.06	Fades	-	SM.03	Movement across picture	Lots, fast
SP.07	Transitions	-	SM.04	Movement up/down	-
SP.08	Slow/fast motion	-	SM.05	Diagonal movement	-
COLOURS & CONTRAST			SM.06	Subjects behind foreground objects	-
CC.01	Light picture	-	SM.07	Low movement	-
CC.02	Dark picture	-	SOUND CONTENT		
CC.03	Bright colours	-	SC.01	Talking	-
CC.04	Dull colours	-	SC.02	Movement	-
CC.05	Fine detail/moiré patterns	-	SC.03	Vehicles	Traffic
CC.06	High contrast areas	-	SC.04	Wind	-
CC.07	Large monochromatic areas	One (sky)	SC.05	Music	-
CC.08	Graininess	-	SC.06	Background	-
CC.09	Black background	-	SC.07	Other	-
CC.10	White background	-	SOUND CHARACTERISTICS		
GLOBAL MOTION			SH.01	Mono/ stereo	Stereo
GM.01	Fast track/pan	-	SH.02	Average volume	Loud
GM.02	Tracking in/out	-	SH.03	Level changes	-
GM.03	Tracking	-	SH.04	Clear/ distorted	-